

SERVICE BULLETIN NO. OSB1078-162

I. TECHNICAL DETAILS

1.1 Category:

Optional

1.2 Aircraft affected:

G 115C/D	all S/N
G 115E	82086-82185
G 115EG	all S/N

1.3 Time of Compliance:

At owners discretion, recommended during next removal / installation of Main Landing Gear legs.

1.4 Subject:

ATA-Code:	32-00 Landing gear
	32-10 Main landing gear

1.5 Reason:

Frequent removal of the outer Main Landing Gear Attachment Bracket may result in reduced locking capability of the respective nuts. This Service Bulletin introduces additional safety plates to secure the MLG attachment bracket bolts.

1.6 Concurrent documents:

N/A

G115C/D G 115E G115EG

1.7 Approval Note:

These information or instructions relate to change no. MÄM 1078-075 which has been approved under the authority of EASA Design Organisation Approval No. EASA.21J.030

The technical information contained in this document has been approved under the authority of EASA Design Organisation Approval No. EASA.21J.030.

1.8 Accomplishment / Instructions:

- 1.8.1. Ensure that the aircraft is safe for parking I.A.W. MM chapter 10-10.
- 1.8.2. Remove MLG legs IAW AMM chapter 32-10.
- 1.8.3. Remove attachment bolts of outer MLG attachment bracket.
- 1.8.4. Inspect MLG attachment brackets for absence of cracks, elongated holes, any other sign of damage, exchange as required
- 1.8.5. Position securing plates (parts 1 & 2 of list 2.1) as depicted, install MLG bracket attachment bolts. For details refer to Fig. 1, 2, & 3.

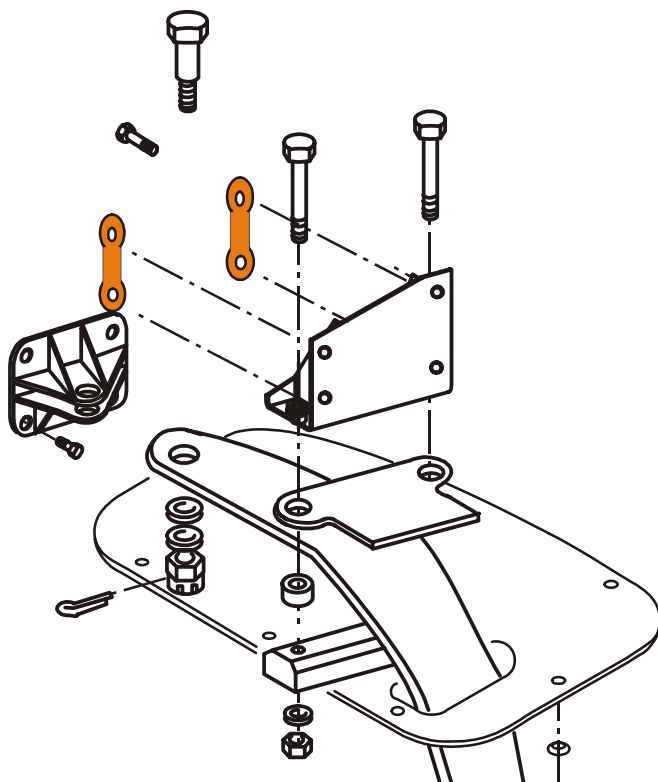

Fig. 1

G115C/D G 115E G115EG



Fig. 2



Fig. 3

1.8.6. Bend safety plate flaps to secure bolts.

Note: Safety plates must not be bent back for subsequent use, for each installation use new plates.

1.8.7. Install MLG legs IAW AMM chapter 32-10.

G115C/D G 115E G115EG

1.9 Repetitive Actions:

N/A

1.10 Mass (Weight) and CG:

N/A

II. PLANNING INFORMATION

2.1 Material & Availability:

Item	Description	P/N	Qty. per A/C
1	SAFETY PLATE	115C-5005.25	2
2	SAFETY PLATE	115C-5005.26	2

2.2 Special Tools:

N/A

2.3 Labour costs:

Modification: approx. 1 hrs

2.4 Reference documents:

G115C/D Maintenance Manual
G115E Maintenance Manual
G115EG Job Guides

2.5 Credit:

N/A

G115C/D G 115E G115EG

III. REMARKS

- 3.1** The correct execution of the instructions may be performed by a competent person/ an authorised aviation workshop and has to be certified in the logbook by an authorised inspector.
- 3.2** The Maintenance Manual and Illustrated Parts Catalogue will be updated to reflect the changes.
- 3.3** If you have sold your aircraft in the meantime, would you kindly pass this information on to the new owner and forward his address and aircraft S/N to us.
- 3.4** For questions and assistance please contact:

Michael Reinhold, Customer Service
phone: +49 8268 998 105
fax: +49 8268 998 200
e-mail: productsupport@grob-aircraft.com

G115C/D G 115E G115EG